

Design and Implementation of a FLC for CD-CD Converters Using a Microcontroller for PV Systems

Gerardo Martínez-Teran, Abel García-Barrientos,
and Francisco Rafael Trejo-Macotela
LIREA, Mechatronics Department, Polytechnic
University of Pachuca, Zempoala, Hidalgo, Mexico
E-mail: abel@upp.edu.mx

Felipe Coyotl-Mixcoatl and Rubén Tapia-Olvera
Electrical Engineering Department, Polytechnic
University of Tulancingo, Tulancingo, Hidalgo, Mexico
E-mail: felipe.coyotl@upt.edu.mx,
ruben.tapia@upt.edu.mx

Abstract— This paper presents the design and implementation of a simple fuzzy logic controller (FLC) for a DC-DC buck converter based on the PIC18F4550 microcontroller to control the lead acid battery charging voltage in solar cells applications. For cost consideration, an inexpensive 8-bit microcontroller is selected to program and implement the FLC proportional-integral. The obtained simulation and experimental results show the viability of the controller with a variation on the load of the buck converter showing a good performance on the design of the FLC, and it has also a smooth response with a small overshoot.

Keywords— DC-DC converters, fuzzy logic control, and Microcontroller.

I. INTRODUCTION

Photovoltaic systems users are searching inexpensive devices; one option is using DC-DC buck converters based on microcontrollers to control the lead acid battery charging voltage. Fuzzy control methods can be easily carried out using an inexpensive 8-bit microcontroller. In ref. [1-4], a controller for DC-DC converters was designed and implemented using the triangular membership functions. Moreover, in ref. [5-6], it has been investigated that how using a fuzzy controller can be controlled the maximum and average current of a DC-DC converter. In most of references due to the complex calculations, the membership function is considered triangular. The effects of different types of membership function such as triangular, Gaussian, bell and trapezoidal for fuzzyfication are investigated in ref. [7], in control of DC-DC converters and the dynamic responses are compared. For this reason, it is necessary to propose robust and inexpensive controllers capable of compensating the dynamics of these systems. The DC-DC converters are devices that regulate electric potential between two devices, this kind of systems are used to load their electricity supplies in devices such as hybrid cars and solar cell devices with rechargeable batteries.

In this paper, a fuzzy controller has been designed for a DC-DC converter and has been tested experimentally. FLC design incorporates Mamdani's implication method of inference, which is one of the most popular methods in fuzzy control applications, the obtained simulation and experimental results show the viability of the controller with a variation in the load of the buck converter, showing a good performance on the design of the FLC, and it has also a smooth response with a small overshoot. The remainder of the paper is organized as follows. The modeling of the buck coveter is given in Section

II. Section III describes the fuzzy control algorithm used for programming the microcontroller. The physical implementation of a buck-type converter based on microcontroller, and the simulation and experimental results performed on a buck-type converter to control the lead acid battery charging voltage in solar cell applications, are presented in Section IV. The conclusions of this work are given in the last section.

II. MODELING OF THE BUCK CONVERTER

The mathematical model of the buck converter is made assuming that it works in continuous conduction mode (CCM), the equivalent circuit is showed in figure 1, where iL is the inductor current, V_o is the output capacitor voltage, V_s is the input voltage source, L is the inductance, C is the capacitance of the output filter, R is the output load resistance and u is the signal control which represents the switch position. For this case, the inductor current is never less than 0 and the voltage on the capacitor has a constant value and a fluctuating part about average value [8]. This operating condition is linked to the inductance values, the load resistance of the converter, and the switching frequency. The technique used to obtain the model of buck converter is based on defining two operating conditions of the MOSFET [9]: When the switch is on position $u = 1$, the circuit is connected to the DC input source resulting an output voltage across the load resistor. If the switch changes its position $u = 0$, the capacitor voltage will discharge through the load, see figure 1. By controlling the switch position in the buck converter, one can obtain the desired output.

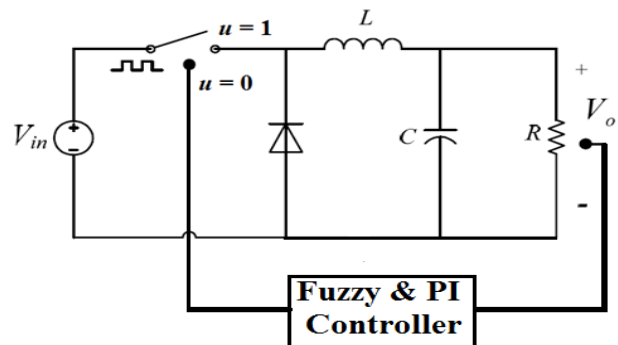

Fig. 1. The schematic of buck converter controllers

The generalized state-space averaging model of uncontrolled buck converter under the continuous conduction

mode for zero-order approximation (set $k = 0$ in (1)) is given by

$$\frac{di_L}{dt} = -\frac{V_o}{L} + \frac{V_{in}}{L}u \quad (1)$$

$$\frac{dV_o}{dt} = -\frac{V_o}{RC} + \frac{i_L}{C} \quad (2)$$

where the equation (1) is when $u = 1$ and the equation (2) is when $u = 0$. More details on how to derive the generalized state-space averaging model in (1) and (2) can be found in [9]-[11].

III. FUZZY LOGIC CONTROL DESIGN

Through a FLC, an expert might be able to control a process based on his knowledge and observation of it, even without any mathematical model. The FLC has the following components: The fuzzification: converts the real input values to fuzzy values to be interpreted by the inference mechanism. The rule-base (*a set of if-then*: which contains the fuzzy values by means of a linguistic description of the expert to achieve good control. Inference mechanism: emulates the expert's decision making in the interpretation and application of knowledge about the best way to control the plant. Finally, the defuzzification: takes the values of the inference mechanism and converts them into actual output values. To carry out FLC design it is necessary to define the following inputs of FLC; the first input is the error ($e(k)$) given by the equation (3), where $V_o(k)$ is the sampled output voltage of the buck converter through the analog to digital converter (ADC) in microcontroller and V_{ref} is the voltage reference. The second input ($ce(k)$) is given by the equation (4) where $e(k)$ is the error at the k_{th} sampling and $e(k-1)$ is the error at the previous k_{th} sampling.

$$e(K) = V_{ref} - V_o(K) \quad (3)$$

$$ce(K) = e(K) - e(K - 1) \quad (4)$$

Inputs are multiplied by gains g_0 and g_1 , respectively, and then they are evaluated in the fuzzy controller. The FLC output is the change in the duty cycle $\Delta d(k)$, which is given by the equation (5), and it is scaled by the gain h .

$$d(k) = d(k - 1) + h\Delta d(k)T_s \quad (5)$$

The gains in the controller inputs and output are from -1 to 1, because they are normalized, it facilitates the controller tuning. The method to calculate PMW duty cycle is through FLC output in the k_{th} sampling ($\Delta d(k)$) and adding to the duty cycle at the previous k_{th} sampling ($d(k-1)$), this method represents discrete time integration in the FLC output. The integration at the FLC output increases the system type and reduces the steady-state error, smoothing the control signal. If the range of integrator is limited, the windup effect is avoided. So it becomes an incremental fuzzy controller [12]. The incremental design approach provides an alternative for genetic fuzzy system in cases where the complexity of the control problem does not allow the evolutionary algorithm to adapt the entire fuzzy knowledge in one step. The diagram of the incremental fuzzy controller is showed in figure 2.

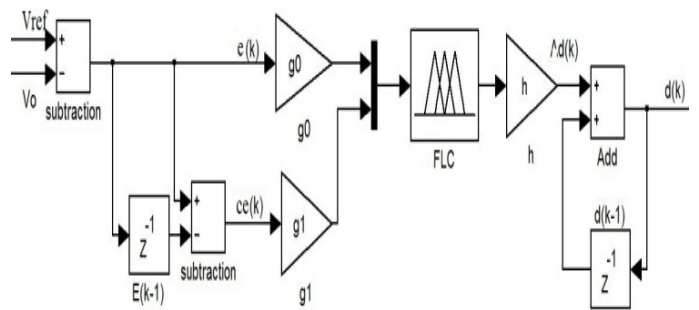

Fig. 2. Schematic diagram of fuzzy logic controller with gains and one integrator in the output

A. Fuzzification

The fuzzification converts the numeric input into a linguistic variable by means of fuzzy sets that are defined into the universe of discourse, taking the next linguistic values: negative big (NB), negative small (NS), zero (Z), positive small (PS) and positive big (PB) for e and ce , the membership functions are showed in figure 3.

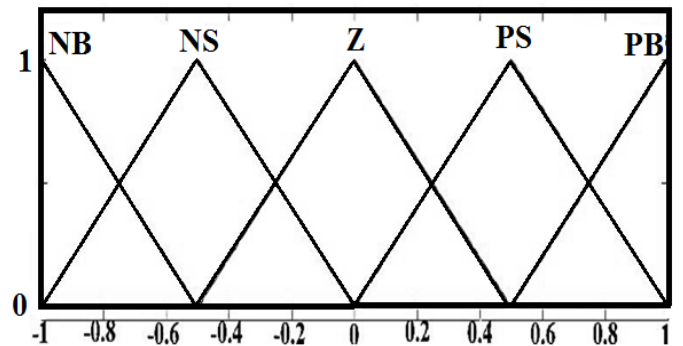

Fig. 3. Triangular type membership functions for e and ce

The fuzzy logic controller uses trapezoidal membership functions in the extremes in order to eliminate discrepancies, and it also uses triangular membership functions at the center, normalized from -1 to 1 for both cases.

B. Rule Base

The rule base is defined by the relations between the inputs and output with rules of type *IF-THEN*. In our case, the designed controller has 5 fuzzy sets for each linguistic variable, which generates 25 rules that can be expressed as a Mamdani linguistic fuzzy model, like in the equation (6)

$$\text{if } e \text{ is } A_{i1} \text{ and } ce \text{ is } A_{i2}, \text{ Then } \Delta d_i \text{ is } B_i \quad (6)$$

where e and ce are the input linguistic variables, Δd_i is the output linguistic variable, A_{i1} and A_{i2} are the values for each input linguistic variables on the universe of discourse and B is the value in output in the universe of discourse. The rules are based by heuristic knowledge in the behavior of the DC-DC converter, which when the voltage is less than the reference, it is necessary increase the duty cycle, and when the voltage is higher than the reference the duty cycle is reduced. In addition, by considering the differential component, the speed at which the error is approaching to the reference can be described. The rule base is showed in the Table 1.

C. Inference Mechanism

The inference mechanism of Mamdani controller is based on generalized modus ponens through cartesian intersection of membership grades e and ce (ue and uce) and applying the Mamdani's min fuzzy implication where the result of inference mechanism is w_i , and c_i is taken from the rule base, like in the equation (7). Some controlling rules considered in this paper are shown in Table 1.

$$w_i = \min\{ue(i), uce(j)\} * c_i \quad (7)$$

TABLE I. CONTROL RULES.

		ce				
		NB	NS	Z	PS	PB
e	NB	-1	-1	-1	-0.5	0
	NS	-1	-1	-0.5	0	0.5
	Z	-1	-0.5	0	0.5	1
	PS	-0.5	0	0.5	1	1
	PB	0	0.5	1	1	1

D. Defuzzification

In the defuzzification operation a logical sum of the inference result from each of the four rules is performed. In this study means of Mamdani's method is implemented. The defuzzification converts the conclusions of the inference mechanism into actual inputs for the process. Which can be developed by the center of gravity method for Mamdani type showed in the equation (8), where b_i is the center of the membership function and $\int u(i)$ denotes the area under the membership function $u(i)$ and it is calculated using the equation (9), with w as the width of the base of the membership function and the height H .

$$\Delta d(k) = \frac{\sum b_i \int u(i)}{\sum \int u(i)} \quad (8)$$

$$\int u(i) = w \left(H - \left(\frac{H^2}{2} \right) \right) \quad (9)$$

One can see the control surface in Figure 4. This displays the output for each one of the possible inputs of e and ce in the FLC.

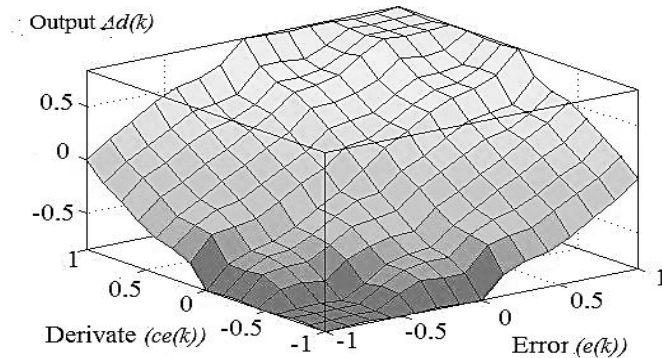

Fig. 4. Fuzzy levels for output signal versus e and ce for triangular type membership function.

IV. RESULTS

The fuzzy controller designed in previous parts is implemented on a BUCK converter. For this purpose, an 8-bit PIC18F4550 microcontroller has been used. According to Fig.1, the available values in Table 1 are used as duty cycles for each error and change in error. The buck converter was built using a MOSFET IRF3710, a diode MBR2060, an inductor with 32 μ H, a capacitor value of 1000 μ F and a load resistor of 22 Ω in the output. The input voltage and the reference are 10 V and 2 V, respectively. The mathematical model was simulated through simulink module – SimPowerSystems in MathLab and the FLC was also designed using the Fuzzy toolbox and Simulink-Fuzzy logic toolbox. In the Figure 5, one can see the general diagram of the buck converter with the FLC in closed loop, and the physical implementation of the buck converter with the FLC programmed on the microcontroller, is showed in Figure 6.

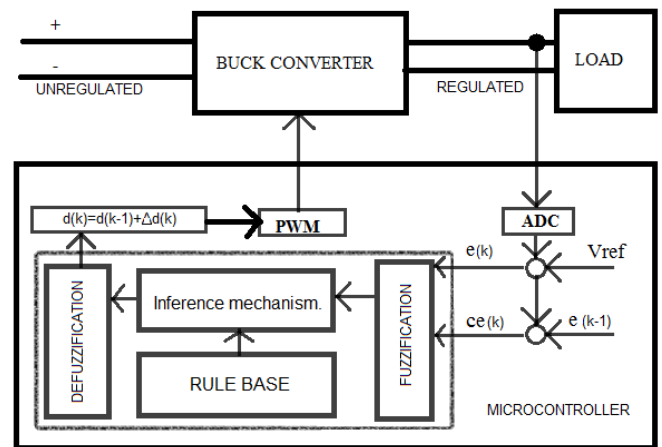

Fig.5. FLC in close loop for buck converter.

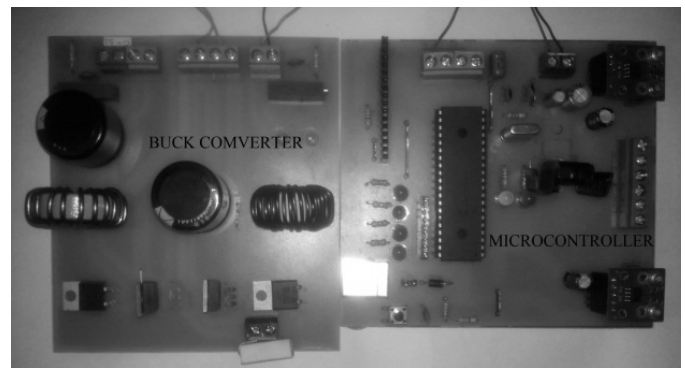
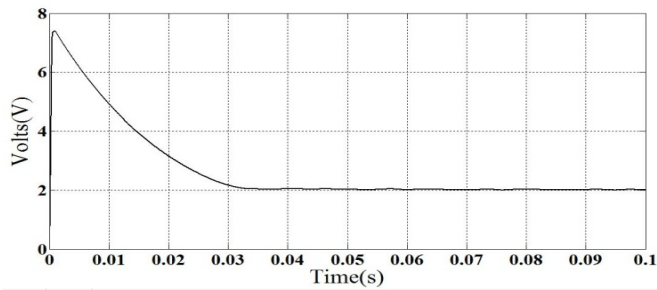

Fig. 6. Physical implementation of buck converter with microcontroller

To verify the effectiveness of the simulation model, an experimental set up is developed, see Figure 6. The buck-boost circuit with MOSFET as a switching component is developed. The fuzzy logic controller to generate duty cycle of PWM signal is programmed. The simulation and experimental results show that the output voltage of the buck-boost converter can be controlled according to the value of duty cycle. The experimental results are concurrent with simulation model. The Fig. 7 shows the output voltage startup transient of the buck

converter, with the previously mentioned values. The setting time is about 30 ms, one can see the experimental results are in agreement with the simulations. This value is adequate to battery charging voltage in solar cells applications.



(a)

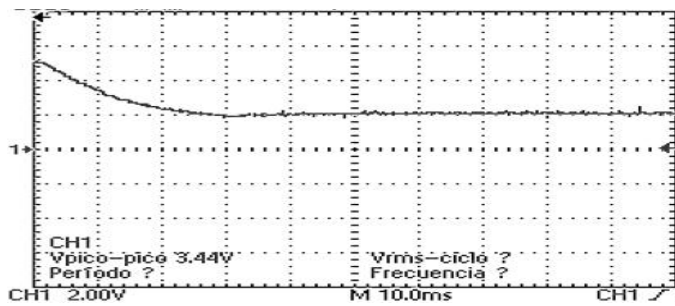

(b)

Fig. 7. Output voltage startup transient of the buck converter with a reference voltage, $V_{ref} = 2$ V. (a) Simulation and (b) Experimental result.

In the Fig.8, the buck converter is subjected to a change in the load resistor, from 22Ω to 220Ω . The startup transient takes approximately 25 ms.

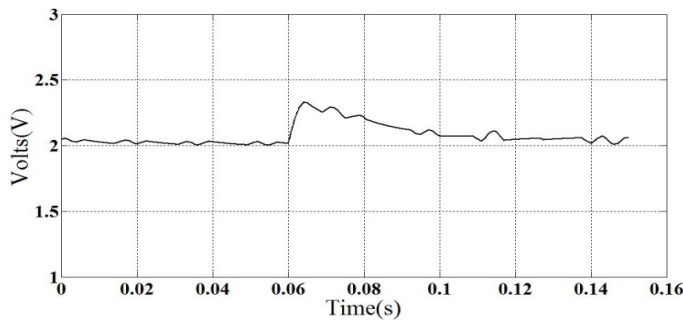

(a)

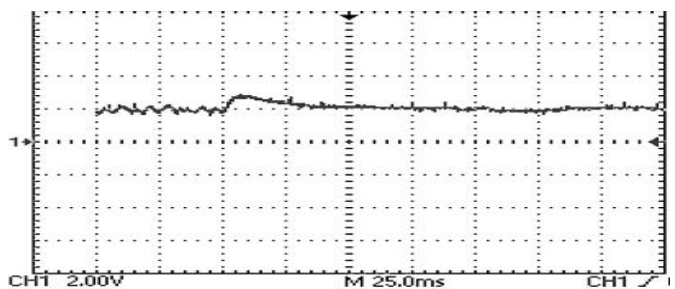

(b)

Fig. 8. Output voltage startup transient of the buck converter subjected to a change in load resistor (22Ω to 220Ω). (a) Simulation and (b) Experimental result.

V. CONCLUSIONS

The design and implementation a fuzzy logic controller for a DC-DC buck converter based on the PIC18F4550 microcontroller to control the battery charging voltage in solar cells applications was carried out successfully. For cost consideration, an inexpensive 8-bit microcontroller was selected to program and implement the FLC proportional-integral, it provides inexpensive photovoltaic systems. The fuzzy controller is able to stabilize at a reference voltage in a time of 30 ms, approximately. If the buck converter is subjected to a change in the load resistor, the fuzzy controller takes approximately 25 ms to stabilize the system.

ACKNOWLEDGMENT

This project has been funded by PROMEP: Redes Temáticas de Colaboración under the project titled: Fuentes de Energías Alternas and by the ECEST-SEP (Espacio Común de Educación Superior Tecnológica) program under the mobility scheme for professors and students, and also it has been partially funded by the CONACyT-Mexico grant CB-169062.

REFERENCES

- [1] Gupta, T., R.R. Boudreaux, R.M. Nelms, J.Y. Hung, "Implementation of a fuzzy controller for DCDC converters using an inexpensive 8-bit microcontroller", *IEEE Trans. on Industrial Electronics*, Vol. 44 No.5, pp. 661-669, 1997.
- [2] Perry, A.G., Feng. Guang, Liu. Yan-Fei, P.C. Sen, "A Design Method for PI-like Fuzzy Logic Controllers for DC-DC Converter" *IEEE Trans. on Industrial Electronics*, Vol. 54, No. 5, pp. 2688-2696, 2007
- [3] Liping, Guo, J.Y. Hung, R.M. Nelms, "Evaluation of DSP-Based PID and Fuzzy Controllers for DC-DC Converters", *IEEE Trans. on Industrial Electronics*, Vol. 56, No. 6, pp. 2237- 2248, 2009.
- [4] Kuo-Hsiang Cheng, Hsu Chun-Fei, Lin Chih-Min, Tsu-Tian Lee and Li Chunshien, "Fuzzy-Neural Sliding-Mode Control for DC-DC Converters Using Asymmetric Gaussian Membership Functions", *IEEE Trans. on Industrial Electronics*, Vol.54, No.3, pp. 1528 - 1536, 2007.
- [5] He, D., R.M. Nelms, "Fuzzy logic peak current-mode control for dc-dc converters using an inexpensive 8-bit microcontroller", *Applied Power Electronics Conference and Exposition*, Vol. 3, pp. 2000 - 2006, 2005.
- [6] He, D., R.M. Nelms, "Fuzzy logic average current-mode control for DC-DC converters using an inexpensive 8-bit microcontroller", *IEEE Trans. on Industry Applications*, Vol. 41, No. 6, pp. 1531-1538, 2005.
- [7] Sarabadani, H., H. Feshki, R.D. Habibinia and Valipour Ebrahimi, "Investigating effects of Different types of membership function for fuzzyfication in control of DC-DC converters", *First International Power Engineering and Optimization Conference (PEOCO2007)*, 2007.
- [8] Ned Mohan, Tore M. Undeland, William P. Robbins, *Electronica de Potencia Convertidores, Aplicaciones y Diseño*, 2nd Edition, New York, Mc Graw Hill, pp. 142-175, 1989.
- [9] J. Mahdavi, A. Emadi, M.D. Bellar, and M. Ehsani, "Analysis of Power Electronic Converters Using the Generalized State-Space Averaging Approach," *IEEE Trans. on Circuit and Systems.*, Vol. 44, pp.767-770, 1997.
- [10] A. Emadi, "Modeling and Analysis of Multiconverter DC Power Electronic Systems Using the Generalized State-Space Averaging Method," *IEEE Trans. on Indus. Elect.*, Vol. 51, No. 3, pp. 661-668, 2004.
- [11] A. Emadi, M. Ehsani, and J.M. Miller, "*Vehicular Electric Power Systems: Land, Sea, Air, and Space Vehicles*," Ed. CRC Press, pp. 520 2003
- [12] Shyama M., "*Digital Linear and Nonlinear Controller for Buck Converter: Fuzzy Controlled Buck Converter*", Ed. Lambert Academic Publishing, pp. 76, 2012 .